

DOWNLOAD DATE: APRIL 15,2006

TABLE OF CONTENTS

CHAPTERS

1.GENERAL POLICIES.....	5
1.1 General Guidelines.....	5
1.2 Classified Material.....	5
1.3 Theses Containing Potentially Patentable Information.....	6
1.4 Referencing The Previous Work of Others and Plagiarism.....	6
2.FORMAT AND APPEARANCE.....	7
2.1 Paper	7
2.2 Margins.....	7
2.3 Font.....	7
2.4 Spacing.....	7
2.5 Duplication.....	8
2.6 Corrections.....	8
2.7 Centering.....	8
2.8 Word and Text Divisions.....	8
2.9 Pagination.....	8
2.10 Multiple Volumes.....	9
2.11 Binding.....	9
3. SPECIFIC GUIDELINES FOR THE PARTS OF THE THESIS.....	10
3.1 Preliminary Pages.....	10
3.1.1 Title page.....	10
3.1.2 Approval page.....	11
3.1.3 Plagiarism page.....	11
3.1.4 Abstract.....	11
3.1.5 Öz.....	11
3.1.6 Dedication, Acknowledgements, and Preface.....	11
3.1.7 Table of contents.....	12
3.1.8 List of tables.....	12
3.1.9 List of figures / list of illustrations / list of schemes.....	12
3.1.10 List of symbols and/or abbreviations.....	12
3.2 The Text.....	12
3.2.1 Illustrative material.....	13
3.2.2 Formulas.....	14
3.2.3 Quotations.....	15
3.2.4 Footnotes and endnotes.....	16

3.3 The Reference Material.....	16
3.3.1 Bibliography or references.....	16
3.3.2 Appendices.....	17
3.3.3 Vita.....	17
4. SYTLE.....	18
APPENDICES	
Appendix A: Sample Front Cover and Spine.....	19
Appendix B: Sample Title Page.....	20
Appendix C: Sample Approval Page.....	21
Appendix D: Sample Plagiarism Page.....	22
Appendix E: Sample Abstract.....	23
Appendix F: Sample Öz.....	24
Appendix G: Sample Dedication Page.....	25
Appendix H: Sample Acknowledgments Page.....	26
Appendix I: Sample Table of Contents.....	27
Appendix J: Sample List of Tables.....	28
Appendix K: Sample List of Figures.....	29
Appendix L: Sample Vita.....	30
Appendix M: Properties of the Thesis Bound	31
Thesis Checklist.....	32
Index.....	33

CHAPTER 1

GENERAL POLICIES

Every thesis accepted for a graduate degree is a mature piece of original research. Just as the research must be precise and complete to meet academic standards of your graduate program, the presentation of that research must be equally precise and complete to meet Graduate School standards.

The purpose of guidelines presented here is to ensure that every thesis which will carry the name of Middle East Technical University meets the same high standards of presentation in terms of all pertinent physical properties, including format, as well as paper and print quality. These standards are Graduate School standards of Middle East Technical University (METU) and are applied consistently to **all** theses conducted in all graduate programs at METU. The current guidelines specified by this manuscript and the “style manual” relating to other sections not specified in this manuscript, which is agreed upon by the student and the advisor or specified by the candidate’s major department, will be strictly adhered to throughout the thesis.

1.1 General Guidelines

All theses must be prepared electronically by using an appropriate word processor and drawing software. It is also required to submit an electronic copy of every thesis to the METU Library. **The requirements of METU Library can be found on <http://www.lib.metu.edu.tr>.** Even though several advantages of using a word processor while preparing a written document are well-recognized, it should be kept in mind that the various limitations involved (of software and hardware, as well as those of the user) all too often lead to unexpectedly poor results. In other words, such use should never be considered an automatic guarantee of acceptable results; nor does it absolve the candidate from the responsibility of meeting the standards set out in this manual. Therefore, it is important that you read and understand the guidelines presented here before the preparation of your thesis. Beware that the guidelines put down here are strictly observed by the Graduate School and manuscripts which do not follow these guidelines will not be accepted by the Graduate School.

Do not use previously approved theses as a guide to the preparation of your own manuscript unless it exactly meets the current guidelines. The current guidelines will be enforced.

For any and all instances not explicitly covered by this manual, a written approval of the Graduate School must be obtained.

1.2 Classified Material

The release of a thesis containing classified material to the public can be restricted by the decision of the Executive Committee of the Graduate School upon a joint application of the candidate and

his/her thesis supervisor. The length of such a classified period is one year at most. However, it may successively be extended through a similar process each time.

1.3 Theses Containing Potentially Patentable Information

If your thesis contains potentially patentable information, you may request a maximum duration of 90 days hold on the release of your thesis to the public. If this request is accepted by the Executive Committee of the Graduate School, your thesis will not be released to the public during this period. The hold period begins immediately after the official graduation date.

1.4 Referencing The Previous Work of Others and Plagiarism

In academic writing, referring to works of other authors is a requirement of academic integrity. Referencing is a matter of honesty and crediting others for their previous ideas and work; but it is also a matter of credibility of your work, in other words, an evidence of the fact that you are aware of what was done on the topic you have been dealing with in your thesis.

Using ideas and research findings of others, and yet pretending that they are your own is **plagiarism**, which is not only immoral but also a **crime**. Therefore, great care must be given to using a proper style in writing your manuscript so that your original work and work of others are clearly distinguishable without any ambiguity, and that all ideas and work of others used in your study are meticulously referenced.

Information about plagiarism can be found on <http://www.fbe.metu.edu.tr>.

CHAPTER 2

FORMAT AND APPEARANCE

Every thesis which will carry the name of Middle East Technical University must meet the same high standards of presentation in terms of all pertinent physical properties, including format as well as paper and print quality. The following guidelines are related to the format and appearance of the thesis that you are going to prepare.

2.1 Paper

All copies of the thesis must be on good quality white bond paper, of at least 75 g, measuring 210 by 297 mm (A4) to insure durability, permanency, and opacity. Only single-sided copies will be accepted for the two copies that will be given to Graduate School for METU Library and Higher Education Council (YÖK) Library.

2.2 Margins

The left margin (binding side) must be at least 4 cm wide to allow for binding; other three margins must be at least 2.5 cm wide. ***Narrower margins are not acceptable.*** Slightly larger margins are advisable, to compensate for small printing shifts during reproduction. ***Absolutely nothing must appear in the margins.*** This means that headings, page numbers, text, tables, illustrations, etc. must all be contained completely within the area bounded by the margins.

2.3 Font

The font size should be 10-point or larger. Any standard font (e.g., Arial, Bookman, Palatino, Tahoma, Times New Roman, and Verdana) is acceptable. Do not use script or ornamental fonts. ***The font type and font size must be consistent throughout the thesis.*** Bold face letters, symbols, and italics may be used for special emphasis and foreign words.

In the body of the thesis, fonts and/or point sizes different from the rest of the text may be used to set off chapter titles, section headings, footnotes, endnotes, examples, quotations, tables, and charts, as long as their use is consistent and they are easily readable.

All theses must be printed by using laser printers. ***If you are uncertain about the quality of your printer, bring a sample page to the Graduate School for review.*** All print must be in permanent black ink and must appear on one side of each page only.

2.4 Spacing

The general text of the manuscript must use 1.5 spacing (department consent can be used for single spacing for large volume theses); although tables, long quotations, footnotes, endnotes, bibliographies, and captions may be single-spaced.

If a right justification is used without hyphenation, texts containing long technical and scientific words may result in unsightly white spaces between words, which are not acceptable. In such cases, a proper word division must be used for those long words, manually.

2.5.Duplication

Submission of the original copy is not required. However, all copies must be made from the same original, and all pages must have a high contrast with consistently dark print throughout the thesis. The print must be permanent; it must not smudge. ***Inferior copies or copies not made on approved paper will not be accepted.*** It is recommended that you work with a reputable copying firm or bindery when having your thesis reproduced.

2.6 Corrections

No ink corrections, strikeouts, correction fluid, correction tape, paste-ups, insertions between lines, or letterset are permitted on the final bound copies. If you must make corrections, make them on the original manuscript (but not by ink corrections or strikeouts which are never allowed) before it is copied for reproduction.

2.7 Centering

All materials must be centered between the text margins rather than between the paper edges. After the manuscript is bound, the centered material will appear to be centered on the page.

In paragraphs, two types of formatting can be used. If spacing between paragraphs is used, then there is no need for indentation. If indentation is used, then no spacing must be used between paragraphs.

2.8 Word and Text Divisions

If any hyphenation is used, words must be divided correctly at the end of a line and may not be divided from one page to the next. Use a standard dictionary (American or British) to determine the correct word division. At least two lines of a paragraph must appear together at the top and bottom of every page. All headings and subheadings must be followed by at least two lines of a paragraph.

2.9 Pagination

All page numbers must appear in the same location. In any case, page numbers must be at least two single spaces above or below the nearest line of text, but within the margin boundaries as stated above. All page numbers must be in the same font and point size.

The following pagination rules must be used:

- For the preliminary pages, use small Roman numerals (i, ii, iii, iv, etc.). The Title page and the Approval page do not have numbers but count as pages i and ii, respectively. Actual page numbering begins with "iii" on the Plagiarism page.
- Use Arabic numerals beginning with "1" on the first page of the text and continue throughout the rest of the thesis, including bibliography, appendices, and vita. ***All pages must be numbered consecutively, including pages containing illustrations, tables, figures, plates, and photographs.***

2.10 Multiple Volumes

If a finished manuscript exceeds 5 cm in thickness it must be bound in two or more volumes, each limited to 5 cm in thickness, too. All volumes must be numbered consecutively, using capital Roman numerals. Each additional volume must contain a title page. Title pages should be identical except for the notation Volume I, Volume II, etc., just below the title to differentiate the volumes.

Both the Roman and the Arabic numbering systems used in Volume I should continue through Volume II. As with the title page of Volume I, that of Volume II counts among the preliminary pages but does not bear a number. If "iv" is the last Roman numeral used in Volume I, for example, the title page of the second volume will count as page "v" and will be followed by preliminary pages "vi", "vii", etc. Each volume must contain a complete Table of Contents.

2.11 Binding

All master's theses are to be bound in black cloth. All doctoral theses are to be bound in red cloth. Synthetic, leatherette, or similar cloths are not acceptable. A bound copy of the thesis should measure 215 by 285 mm.

See Appendix A for a sample front cover and spine and Appendix M for the bound.

A list of authorized binderies can be obtained from the Graduate School. It is your responsibility to have the pages of the text in correct order when it is submitted to the bindery.

CHAPTER 3

SPECIFIC GUIDELINES FOR THE PARTS OF THE THESIS

Two general rules of thumb should govern the presentation of any thesis:

- keep the format as simple as possible, and
- be consistent with the format throughout the thesis.

Every thesis has three main parts or divisions: the preliminary pages, the text, and the reference material. You must follow the order of items within these parts as listed below. *Required sections are marked with an asterisk.*

PRELIMINARY PAGES

- * Title Page
- * Approval Page
- * Signed Plagiarism Page
- * Abstract
- * Öz
- Dedication
- Acknowledgments
- Preface
- * Table of Contents
- List of Tables
- List of Figures/ List of Illustrations/List of Schemes
- List of Symbols and/or Abbreviations

TEXT

- * Main Body

REFERENCE MATERIAL

- * Bibliography or References
- Appendices (may be placed before Bibliography or References)
- * Vita (required only for doctoral theses)

3.1 Preliminary Pages

3.1.1 Title page

The title must be single-spaced, in all capital letters, and should begin at 3.5 cm from the top of the page. If necessary, long titles can be written in multiple lines avoiding unnecessary line breakages. Information retrieval systems consulted by many scholars to locate theses and dissertations relating

to their own work use key words in the title. Consequently, *the title must not contain any chemical or mathematical formulas, symbols, or other non-standard abbreviations or character if it is not possible to print them on cover page. Thus, such information must be substituted for words.*

The format of the title page, including spacing and capitalization must be exactly as in the sample title page shown in Appendix B.

3.1.2 Approval page

A sample approval page is provided in Appendix C. It is strongly recommended that the approval page of the thesis be signed in **blue ink**.

3.1.3. Plagiarism page

This page includes the statement signed by the author about plagiarism. A sample plagiarism page is provided in Appendix D.

3.1.4 Abstract

The abstract should appear on a separate page and be independent of the remainder of the thesis. An abstract should start with a clear statement of the object or purpose of the work done. The objective of the abstract is to furnish the reader, who may not be intimately concerned with details of the study, its purpose, results, important conclusions, and recommendations. As an example, the experimental equipment used with its size and type; a brief description of the experimental method and the important parameters must be given if appropriate. Major quantitative and qualitative results and main conclusions should be covered within the abstract using a few short sentences for each without any subheadings. The abstract requires clear, concise and quantitative statements of what was done, what was found, and what it means. Writing an abstract requires a great deal of thought and is best done after completion of the other sections of the manuscript.

An abstract must not exceed 250 words, must not include any diagrams and references, nor any mathematical formulas unless absolutely essential.

Maximum five keywords must be written at the end of the abstract.

A sample abstract is provided in Appendix E.

3.1.5 Öz

Öz is the Turkish translation of the abstract. A sample Öz is provided in Appendix F.

3.1.6 Dedication, acknowledgments, and preface

If included, each of these items must appear on a separate page. A heading for the dedication is not required, but it must have a page number. If used, the dedication must be brief and centered on the page. A sample dedication is provided in Appendix G.

Like the dedication, acknowledgments and preface are optional. They must have headings and should use the same spacing as the text (i.e., 1.5 spacing). The heading **ACKNOWLEDGMENTS**

or **PREFACE** appears centered between text margins, without punctuation, 3.5 cm from the top of the page; the text begins at least two spaces below the heading.

This page is written to acknowledge the persons who have made a real effort to help the author in the preparation of the manuscript. Any kind of help can be acknowledged.

A sample acknowledgment is provided in Appendix H.

3.1.7 Table of contents

The table of contents must list the title of each chapter and its parts and sections, references or bibliography, appendices, and vita (if applicable). The wording used for all entries in the table of contents must match exactly with what is used in the text. Each entry must have leader dots which connect it to its corresponding page number.

The heading **TABLE OF CONTENTS** appears without punctuation, centered between the text margins, 3.5 cm from the top of the page. The listing of actual contents begins at the left margin at least three spaces below the heading.

A sample table of contents is provided in Appendix I.

3.1.8 List of tables

A list of tables may be included for the convenience of the reader. If included, it will immediately follow the table of contents on a new page.

The heading **LIST OF TABLES** appears centered between the text margins, without punctuation, 3.5 cm from the top of the page; the listing begins at the left margin at least two spaces below the heading.

Each entry should have the same number and the same caption or title used for a table in the text, although a long caption may be abbreviated to the extent of using only the first full sentence. As in the table of contents, each entry must have leader dots which connect it to its page number.

A sample list of tables is provided in Appendix J.

3.1.9 List of figures / list of illustrations / list of schemes

If included, these lists must appear on separate pages and are governed by the same rules as the list of tables. A sample list of figures is provided in Appendix K.

3.1.10 List of symbols and/or abbreviations

If included, you should follow a format consistent with acceptable practice in your discipline.

3.2 The Text

The text, or the main body of a thesis, is divided into multiple chapters to help the reader in understanding the subject matter. Although the detailed organization of the text varies among academic disciplines, the formatting of the text must be consistent throughout. *All headings and*

subheadings should be presented in the same way in each chapter, in terms of capitalization, placement on type page and kind of type used. No headers, giving the titles of chapters or other sections are allowed at the top of the pages, nor any footer at the bottom of pages.

Chapters are numbered consecutively in Arabic or Roman numerals and capital letters (CHAPTER 1, CHAPTER 2, etc., or CHAPTER I, CHAPTER II, etc.). In addition to general titles like INTRODUCTION, the chapters need short but substantially descriptive titles, as well.

Only new chapters should begin with a new page. Within a chapter, the presentation of subsections must be continuous; partially filled pages of text are acceptable only on non-textual pages, such as those presenting tables and illustrations.

The heading CHAPTER I in all capitals is centered between the text margins, 3.5 cm from the top of the page; the title goes two spaces below, centered, and in all capital letters. The text begins at least two spaces below.

In many cases the main body of the thesis will include certain materials other than ordinary text, such as illustrations, formulas, quotations, footnotes, and endnotes. In such cases, the following guidelines should be observed.

3.2.1 Illustrative material

Illustrations include drawings, charts, figures, tables, diagrams, plates, and photographs. These may be inserted wherever the author feels appropriate, but as a general rule, should appear as near as possible to the part of the text which refers to them.

Table numbers and captions are placed one space above the top line of the illustration; figure numbers and captions are placed one space below the last line or bottom of the illustration.

Illustrations of one-half page or less in length may appear on the same page with the text, separated from the text above and below by three space.

Illustrations that are too large to be placed sideways between the left- and right-hand margins should be rotated counterclockwise 90 degrees so that the top of the illustration runs parallel to the left-hand margin of the page. In such a case, the whole page must be reserved only for that illustration. The caption or legend for such an illustration must also be rotated. When illustrations are presented in this manner, the usual margin requirements remain in effect, and page numbers should appear in their normal place.

Illustrations of any kind must be numbered consecutively, including appendices. You may follow a straight sequence (1, 2, 3, etc.) or use a decimal approach (1.1, 1.2, 1.3,..., A.1, A.2, where the first digit is the chapter or appendix number, and the digit after the decimal point is the illustration number within that chapter or appendix).

Illustrations may run longer than one page. In such cases, all subsequent pages of the illustration must include at least the illustration number and the notation that is continued, e.g., "Table 1 (cont'd)" or "Table 1 (continued)".

All headings and captions must be prepared either in the same font and point size used for the text, or in the same font and point size as every other heading and caption. Choose a point size that is easy to read, especially for tables, axis scales, axis titles, legends, and labels in charts and diagrams.

Color may be used in figures and photographs as long as duplicate copies are all produced by color photocopy. Photographic illustrations must be originals or well-made photographic copies of the originals. Standard photocopies of photographs are not acceptable. Wherever required, mounting of illustrations should be done with a technique that ensures durable and good quality result (e.g., dry mounting). With dry mounting, the paper to which photographs are attached will not curl. Other methods, such as library paste, rubber cement, spray mounting, or tape, are not acceptable: such mounting techniques are not permanent, and the adhesives used will eventually destroy both the paper and the photograph in the long run.

If an audio visual material (e.g., videotape, cassette, etc.) is needed to accompany and supplement the text, it should be adequately described within the continuity of the text. Such material will be submitted only with the Departmental copy.

Stored information in the form of CD will be submitted with all copies.

Computer print-outs must conform to the margin specifications, must be dark and legible with high black and white contrast, and must be copied on thesis-quality paper.

Authors may treat oversized materials in one of the following three ways:

- Captions may be placed on a separate page, facing the illustration. Consequently, it is the right margin of a facing page, not the left that must be at least 4 cm for binding purposes. If an oversized illustration is rotated and the caption appears on a facing page, the caption must also be rotated.
- An illustration may be photo-reduced, but its page number and caption must be the same size and font as in the rest of the illustrations.
- An illustration may be folded and inserted in either of the following ways:
 - a) Fold the illustration and insert it in a white or manila envelope no larger than 16.5 by 24cm, which may be mounted on paper of the proper weight for inclusion in the thesis. Each page enclosed in the envelope must be included in the pagination of the thesis; the page on which the envelope is mounted should have a single page number or inclusive page numbers, as needed,or
 - b) Fold the illustration and mount it on 21 by 29.7 cm sheet (see examples given in Figures 3.1 and 3.2).

3.2.2 Formulas

Mathematical and chemical formulas, equations and expressions must be prepared by using an appropriate equation editor. If a reference is made to them, they must carry a numerical

identification. Each equation must be numbered in parentheses and this must be given next to the right margin.

3.2.3 Quotations

Short, direct prose quotations of three lines or less should be incorporated into the text, enclosed in double quotation marks. Prose quotations which exceed three lines should be set off from the text in single spacing and indented in its entirety at least four spaces from the left margin, with no quotation marks at the beginning or end.

Quotations of poetry that are two lines or longer should normally be set off from the text, line for line as in the original and centered between the text margins without quotation marks. Quotations of poetry may be 1.5 or single-spaced, following the original.

Segments of computer programs may be treated as quotations.

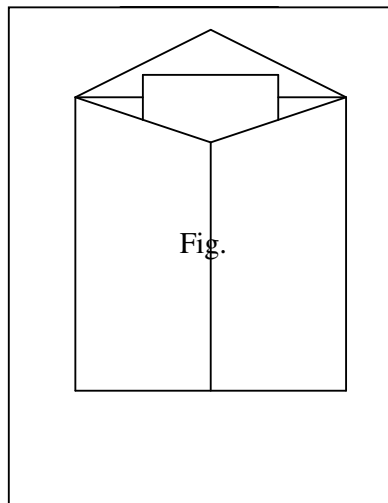

Figure 3.1 An illustration too large to be included may be inserted in a mounted white or manila envelope no larger than 16.5 by 24 centimeters.

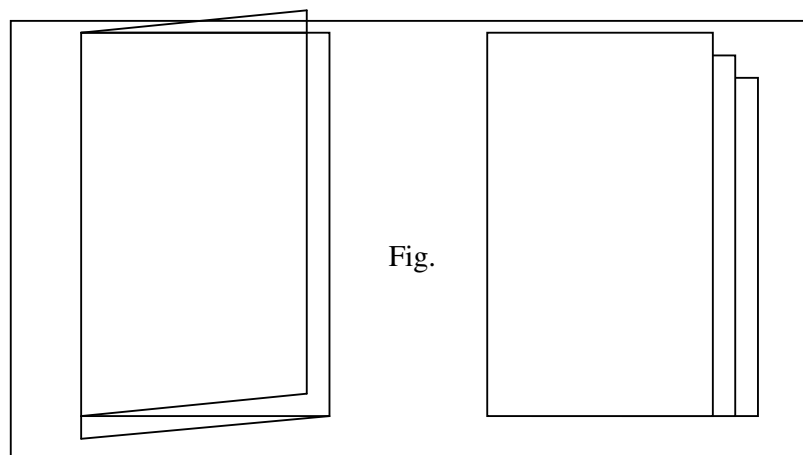

Figure 3.2 A graph or chart extending beyond the page horizontally may be folded fan-wise and mounted on a page. The mounted article, when folded, must still fall within the prescribed margins.

3.2.4 Footnotes and endnotes

Notes may be in the form of footnotes, placed at the bottom of each page, or endnotes, placed at the end of each chapter or at the end of the thesis before the bibliography.

Footnoting practices differ widely among publications in the sciences, humanities, and social sciences. Candidates should consult with their departments regarding accepted footnoting practice in their individual disciplines.

The most common mode of presentation for both footnotes and endnotes is to single-space within, and double-space between, each listing. If placed at the bottom of each page, footnotes must be separated from the text by a complete horizontal line one space above the first line of the footnote.

Arabic numerals, asterisks or small letters should be used for footnotes and endnotes. In either case, the label used may appear either above the line or in parentheses even with the line.

3.3 The Reference Material

The reference material consists of a bibliography or references which is required, and appendices which are optional.

3.3.1 Bibliography or references

A bibliography is a selected list of all books, articles, and other source material related to the thesis research and is always in alphabetical order, with the author's last name first.

In some disciplines it is customary to list all of the references at the end of the thesis in a section headed "References", "List of References", or "Literature Cited" instead of "Bibliography". One of these headings should be used depending upon the departmental choice. The references in the thesis are cited by year, e.g., Smith (1966), or by number, e.g., Smith [3] or [3]. If numbers are used, the listing should be in numerical order, and the author's last name need not be first.

If an internet page is used as a reference source, the last date accessed must be supplied and for "author", owner of the page; for "title", title of the page; for "publisher", URL address; for "date", date of update of the page can be used.

- In certain scientific and engineering disciplines, the references may be given at the end of each chapter instead of at the end of the thesis.
- Do not give the bibliography or references a chapter number, but it must have page numbers written in the same font and point size used for pagination throughout the thesis.
- The heading **BIBLIOGRAPHY** or **REFERENCES** is centered between the text margins, without punctuation, 3.5 cm from the top of the page; the list begins two spaces below.

- Each bibliographic entry should be single-spaced with double spacing between entries.
- *The candidate's program should be consulted for a reference style that is appropriate to the discipline and acceptable to the department.*

3.3.2 Appendices

You may use appendices if you want to present some additional materials but keep the main text free of such details. For example, an appendix may contain test forms, detailed apparatus description, extensive tables of raw data, computer programs, etc.

- If the information to be appended requires more than one appendix, each should be given a letter (Appendix A, Appendix B, etc.). The heading APPENDIX A should appear centered between the text margins, 3.5 cm from the top of the page. The font and point size should be same as those used for chapter titles.
- Spacing need not be the same for each of the appendices. Documents and case studies may be single-spaced, whereas spacing for the explanations of methods and procedures may be similar to that of the text.
- Each appendix with its title must be listed separately in the table of contents as a subdivision under the heading APPENDICES.
- All appendices must have page numbers written in the same font and point size used for pagination throughout the thesis.
- If an appendix contains photocopied material, the photocopies should be of letter quality.

3.3.3 Vita

The vita is required only for doctoral theses. It is a professional biography of the candidate which includes date and place of birth, educational institutions attended (after high school), degrees and honors won, titles of publications, and teaching and professional experience. It should be short, concise, and written in the third person, although in some departments a resume or curriculum vitae may be substituted.

- Note that the correct spelling is either "Vita" or "Curriculum Vitae".
- Do not give the vita a chapter number, but it must have page numbers and be included as the last item in the table of contents.
- The vita must be in the same font and point size as the rest of the thesis.
- A sample Vita is provided in Appendix L.

CHAPTER 4

STYLE

A thesis is a formal research presentation. Hence it should be written in a formal style appropriate to the discipline (e.g., passive voice, impersonal style). Adopt the past tense throughout ("Results of the experiment demonstrated ...") and avoid slang and colloquialisms. Do not use contractions (e.g., can't, shouldn't, won't, etc.) but write each word separately (e.g., can not, should not, will not, etc.) Avoid using the first person singular "I", in order to sustain objectivity throughout the thesis. Technical terms should be used where appropriate, but avoid using words and phrases that are difficult to understand when a simpler vocabulary will do just as well.

Because stylistic conventions vary greatly from one discipline to another, you should consult with your supervisor and/or graduate coordinator regarding recommended style manuals. The most recent editions of the recommended style manuals are given below;

The Chicago Manual of Style, 14th Ed., University of Chicago Press, Chicago, 1993.

Campbell, W.G., Ballou, S.V., and Slade, C., *Form and Style: Theses, Reports, Term Papers, 8th Ed.*, Houghton Mifflin Co., Boston, 1990.

Dodd, J.S., Ed., *The ACS Style Guide: A Manual for Authors and Editors, 2nd Ed.*, American Chemical Society, Washington, 1997.

Gilbaldi, J., *MLA Style Manual and Guide to Scholarly Publishing, 2nd Ed.*, Modern Language Association of America, New York, 1998.

Publication Manual, 5th Ed., American Psychological Association, Washington, 2001.

Scientific Style and Format: The CBE Manual for Authors, Editors, and Publishers, 6th Ed., Cambridge University Press, New York, 1994.

Turabian, K.L., (revised by Bennett, A.), *A Manual for Writers of Term Papers, Theses and Dissertations, 6th Ed.*, University of Chicago Press, Chicago, 1996.

You can find the style manuals in the library or in the bookstore. Summaries and highlights of the rules in particular styles can be found on the internet for a quick check. You may consult the Academic Writing Center about the styles. (<http://www.awc.metu.edu.tr/>)

G. SAĞLIKLI

Appendix A: Sample Front Cover and Spine

ANSWERING THAT PROVERBIAL QUESTION:
"HOW MUCH LONGER WILL YOU BE IN SCHOOL?"

GÜRBÜZ SAĞLIKLI

METU
2004

JANUARY 2004

Appendix B: Sample Title Page

ANSWERING THAT PROVERBIAL QUESTION:
"HOW MUCH LONGER WILL YOU BE IN SCHOOL?"

A THESIS SUBMITTED TO
THE GRADUATE SCHOOL OF NATURAL AND APPLIED SCIENCES
OF
MIDDLE EAST TECHNICAL UNIVERSITY

BY

GÜRBÜZ SAĞLIKLI

IN PARTIAL FULFILLMENT OF THE REQUIREMENTS
FOR
THE DEGREE OF MASTER OF SCIENCE/ DOCTOR OF PHILOSOPHY
IN
INDUSTRIAL ENGINEERING*

JANUARY 2004

*In Department of Architecture, consult the Department for style for this section

Appendix C: Sample Approval Page

Approval of the Graduate School of (Name of the Graduate School)

(Title and Name)
Director

I certify that this thesis satisfies all the requirements as a thesis for the degree of Master of Science/Arts / Doctor of Philosophy.

(Title and Name)
Head of Department

This is to certify that we have read this thesis and that in our opinion it is fully adequate, in scope and quality, as a thesis for the degree of Master of Science/Arts/Doctor of Philosophy.

(Title and Name)
Co-Supervisor

(Title and Name)
Supervisor

Examining Committee Members (first name belongs to the chairperson of the jury and the second name belongs to supervisor)

Prof. Dr. Emine Yeşil	(METU,CHEM)	_____
(Title and Name)	(Affiliation)	_____
(Title and Name)	(Affiliation)	_____
(Title and Name)	(Affiliation)	_____
Ekrem Düzgün	(ASELSAN)	_____

Appendix D. Sample Plagiarism Page

I hereby declare that all information in this document has been obtained and presented in accordance with academic rules and ethical conduct. I also declare that, as required by these rules and conduct, I have fully cited and referenced all material and results that are not original to this work.

Name, Last name :

Signature :

Appendix E: Sample Abstract

ABSTRACT

THE AGONY OF THESIS WRITING: A HISTORY

Üçkök, Mehmet

Ph.D., Department of Secondary Science and Mathematics Education

Supervisor : Prof. Dr. Metin Uygun

Co-Supervisor: Prof. Dr. Nejla Sarı

January 2004, 56 pages

This thesis analyzes the process of writing a thesis in a historical context. Neck cramps, writer's block, frustration and hysteria will be discussed alongside inspired prose, and completed final drafts. The thesis will also trace the history of doctoral requirements and will seek to answer questions such as why we need A4-size paper, who first set the left margin at four centimeters, and the origins of the abstract itself.

Keywords: Thesis Writing, Thesis Format

Appendix F: Sample Öz

ÖZ

TEZ YAZMANIN IZDIRABI: BİR TARİHÇE

Üçkök, Mehmet

Doktora, Orta Öğretim Fen ve Matematik Alanları Eğitimi Bölümü

Tez Yöneticisi : Prof. Dr. Metin Uygun

Ortak Tez Yöneticisi: Prof. Dr. Nejla Sarı

Ocak 2004, 56 sayfa

Bu çalışma, tez yazım sürecini tarihsel bir çerçevede incelemiştir. Tezin, boyun ağrıları, geçici zihin kaybı, umutsuzluk ve sinir krizlerinin yanı sıra, ilham perisinin katkılarıyla ortaya çıkan son taslağı tartışılmıştır. Bu çalışma, doktora derecesi için gerekli koşulların tarihsel sürecini araştırmış, neden A4 boyutlu kağıt kullanıldığı, sol marjinin ilk kez kimin tarafından 4 cm olarak belirlendiği ve özet sayfasının kökeni gibi sorulara yanıtlanmaya çalışılmıştır.

Anahtar Kelimeler: Tez Yazımı, Tez Formatı

AppendixG: Sample Dedication Page

To My Parents

Appendix H: Sample Acknowledgments Page

ACKNOWLEDGMENTS

The author wishes to express his deepest gratitude to his supervisor Prof. Dr. Metin Uygun and co-supervisor Prof. Dr. Nejla Sarı for their guidance, advice, criticism, encouragements and insight throughout the research.

The author would also like to thank Assoc. Prof. Dr. Hasan Türkoğlu for his suggestions and comments.

The technical assistance of Mr.Laçın Ufuk, Mr. Veli Bahadır and Ms.Lerzan Melek are gratefully acknowledged.

This study was supported by the State Planning Organization (DPT) Grant No: BAP-09-11-DPT-2002K125/510.

Appendix I: Sample Table of Contents

TABLE OF CONTENTS

PLAGIARISM.....	iii
ABSTRACT	iv
ÖZ.....	v
ACKNOWLEDGMENTS	vi
TABLE OF CONTENTS.....	vii
CHAPTER	
1. INTRODUCTION	1
2. POLICY DIVERGENCE AND TRADITIONAL RESEARCH.....	5
2.1 Background of a Contrast: Divergence of Long-Term Care Outputs in Rural and Industrial States.....	5
2.2 The Contrast and Its Causes.....	8
2.3 Traditional Studies and the Failure to Provide a Plausible Explanation	13
3. METHODOLOGY, RESEARCH PARADIGMS, AND THE ANALYTIC FRAMEWORKS GOVERNING BASIC ASSUMPTIONS.....	16
3.1 Rationale for the Research Method	16
3.2 Empirical Data and Their Collection.....	18
3.3 Data Analyses.....	23
3.3.1 Curve fitting by regression analysis.....	38
4. CONCLUSIONS.....	47
REFERENCES	51
APPENDICES	
A. RESULTS OF IMPROVEMENT HEURISTICS.....	53
B. DATA FOR SAMPLE MAP GENERATION	64

Appendix J: Sample List of Tables

LIST OF TABLES

TABLES

Table 1 Enviromental Conditions that Influence Swelling Potential	36
Table 2 Occurrence of flecks on leaves of hybrid poplar clones that were given varying doses of ozone	39
Table 3 Sample Properties	43

OR

Table 1.1 Enviromental Conditions that Influence Swelling Potential	48
Table 1.2 Stress Conditions that Influence Swelling Potential	49
Table 10.1 Samples used in the Experimental Study	51

Appendix K: Sample List of Figures

LIST OF FIGURES

FIGURES

Figure 1 Internal Electrochemical System of Soil..... 28

Figure 2 Swelling of Clay Rich Soils 30

OR

Figure 3.1 Preparation of Samples 35

Figure 10.5 Classification Chart for Swelling Potential..... 40

Appendix L: Sample Vita

CURRICULUM VITAE

PERSONAL INFORMATION

Surname, Name: Eryaman, Yaman
Nationality: Turkish (TC)
Date and Place of Birth: 1 April 1976 , Afyon
Marital Status: Single
Phone: +90 312 210 22 92
Fax: +90 312 210 22 91
email: wwwfbe@metu.edu.tr

EDUCATION

Degree	Institution	Year of Graduation
MS	METU Aeronautical Engineering	1999
BS	METU Mechanical Engineering	1996
High School	Atatürk Anadolu High School, Ankara	1992

WORK EXPERIENCE

Year	Place	Enrollment
2003- Present	KLAN Mühendislik	Control Chief
1997-2003	METU Department of Mechanical Engineering	Research Assistant
1995 July	FMC Nurool	Intern Engineering Student
1994 August	Arçelik	Intern Engineering Student

FOREIGN LANGUAGES

Advanced English, Fluent German

PUBLICATIONS

1. Eryaman Y., Savucu S. and Mert M. "Model Predictive Control of a CSTR for Boric Acid Production", Control Journal, 5(12), 225-228 (2004)
2. Eryaman Y., Mert M. "Borik Asit Üretilen Bir Karıştırmalı Tepkime Kabının Model Öngörülen Denetim", TÜBİTAK DOĞA Dergisi, 12(3), 121-125 (2003)

HOBBIES

Tennis, Scuba, Gourmet, Computer Technologies, Movies, Motor Sports

Appendix M: Properties of the Thesis Bound

RULES TO FOLLOW IN THE BINDING OF THE MASTER OF SCIENCE THESES AND DOCTOR OF PHILOSOPHY THESES

1. In the bound of the Master of Science theses, black bound cloth and in the bound of the Doctor of Philosophy theses, red bound cloth must be used.
2. In the covers of the bindings, 1.8 mm cardboard and in the spine 2.5 mm cardboard must be used.
3. The bindings must be stitched by drilling 5 holes with a 2 mm drill. The spine must be drilled together with the binding cloth and then stitched.
4. The paper and the cardboard dimensions must be as follows;

 Paper dimensions : 20.5x28 cm
 Cardboard dimensions: 20.5x 28.5 cm
5. The spine must be flat and the dimension of the spine must be 5 mm larger than the covers.
6. The binding cloth must be cut straight and the inner face of the covers must be covered with domestic Bristol (180 grams).
7. Spine cloth (Şeraze) and the ribbon must be red.
8. A white blank page must be placed after the front and before the back covers.
9. For the letter font on the front cover and the spine of the binding, 33 serail iü font from BARLAN HURUFAT catalog must be used. The writing must be printed with the stamping type writing machine.

THESIS CHECKLIST

- Make sure you follow the rules set forth in this manual in writing your thesis.
- Submit an unbound copy of your thesis together with the Thesis Jury Appointment Form to the Graduate School **at least (10) days** prior to the date of your thesis defense.
- If you are a Ph.D. candidate, make sure your thesis defense is announced in "**Bu Hafta**", **15 days** prior to the date due.
- Be sure to submit the Thesis Defense Form to the Graduate School within three **(3) days** after the defense.
- Make the changes pointed out by the Graduate School and your Jury.
- Submit at least five (5) bound copies of your thesis to Graduate School within **one month** after the defense.
- Be sure to submit the Questionnaire and the two forms (which will be given to Higher Education Council (YÖK) and METU Library) given earlier with the unbound copy of your thesis.
- Be sure to submit a copy of Abstract and Öz.
- The Graduate School keeps one copy for the Council of Higher Education (YÖK). It is your responsibility to distribute the copies of your thesis to METU Library, your advisor and department head. The last copy is for your own use.
- Before going to METU Library with the bound thesis after the all signatures are completed, submit your thesis electronically at the address *http://www.lib.metu.edu.tr* using a PDF formatted CD.
- Obtain Student Registration Withdraw Form from the Registrar's Office and, once all the approvals are completed, return it to the same office along with your Identification Card and a receipt for the Diploma fee.

INDEX

Abstract.....	10,11,23
Acknowledgement.....	10,11,26
Appendices.....	10,17
Approval Page.....	10,11,21
Bibliography.....	16,10
Binding.....	9,31
Bound Thesis.....	31,32
Chapters.....	12,13,27,3
Classified.....	5
Dedication.....	10,11,25
Endnotes.....	16
Equations.....	14
Figures.....	10,12,13,14,15,29
Footnotes.....	16
Format.....	7
Formulas.....	14
Illustrations.....	13,14,10
Margins.....	7
Mutiple Volumes.....	9
Öz.....	10,11,24
Pagination.....	8
Paper.....	7
Patent.....	6
Plagiarism.....	6,11,22
Plates.....	13
Preface.....	10,11,2
References.....	10,16
Spacing.....	7
Style Manuals.....	18
Table of Contents.....	12,27,3
Tables.....	10,12,13,14,15,28
Text.....	8,10,12,13
Thesis Checklist.....	32
Title Page.....	10,11,20
Type.....	7
Vita.....	17,30